

## Half Bridge IGBT Module

$V_{CES} = 1700V$ ,  $I_{C\ nom} = 600A$  /  $I_{CRM} = 1200A$

### Features :

- 1700V Trench /Field Stop process
- Low switching losses
- $V_{cesat}$  has a positive temperature coefficient

### Applications:

- Power Conversion System
- Static Var Generator
- Wind Generatoren

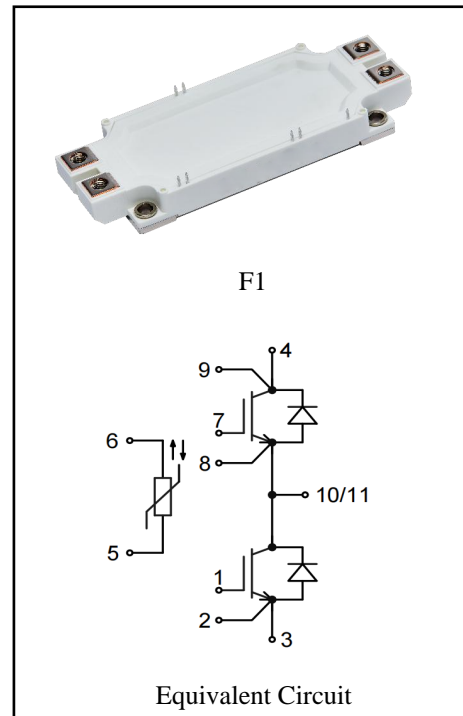

## IGBT, Inverter

### Maximum Ratings

Parameter	Conditions	Symbol	Value	Unit
Collector-Emitter voltage	$T_{vj} = 25^{\circ}C$	$V_{CES}$	1700	V
Continuous DC collector current	$T_C = 100^{\circ}C$ , $T_{vj\ max} = 175^{\circ}C$	$I_{C\ nom}$	600	A
Repetitive peak collector current	$t_p = 1\ ms$	$I_{CRM}$	1200	A
Total power dissipation	$T_C = 25^{\circ}C$ , $T_{vj\ max} = 175^{\circ}C$	$P_{tot}$	4200	W
Gate emitter voltage		$V_{GE}$	$\pm 20$	V

## Characteristic Values

Parameter	Conditions	Symbol	Value			Unit
			Min.	Typ.	Max.	
Collector-Emitter saturation voltage	$V_{GE}=15V, I_C=600A$ $T_{vj}=25^{\circ}C$ $V_{GE}=15V, I_C=600A$ $T_{vj}=125^{\circ}C$ $V_{GE}=15V, I_C=600A$ $T_{vj}=150^{\circ}C$	$V_{CEsat}$		2.08 2.49 2.59	2.50	V
Gate-Emitter threshold voltage	$I_C=24mA, V_{GE}=V_{CE}$ $T_{vj}=25^{\circ}C$	$V_{GE(th)}$	5.30	5.87	6.40	
Gate charge	$V_{GE}=-15V \dots +15V$	$Q_G$		4.48		$\mu C$
Internal gate resistor	$T_{vj}=25^{\circ}C$	$R_{Gint}$		0.75		$\Omega$
Input capacitance	$f=100KHz, V_{CE}=25V, V_{GE}=0V$ $T_{vj}=25^{\circ}C$	$C_{ies}$		75.70		nF
Reverse transfer capacitance		$C_{res}$		0.50		
Collector-emitter cut-off current	$V_{CE}=1700V, V_{GE}=0V$ $T_{vj}=25^{\circ}C$	$I_{CES}$			2	mA
Gate-emitter leakage current	$V_{CE}=0V, V_{GE}=20V$ $T_{vj}=25^{\circ}C$	$I_{GES}$			200	nA
Turn-on delay time	$I_C=600A, V_{CE}=900V$ $T_{vj}=25^{\circ}C$ $V_{GE}=\pm 15V, R_G=1.0\Omega$ $T_{vj}=125^{\circ}C$ (inductive load) $T_{vj}=150^{\circ}C$	$t_{don}$		212 251 261		ns
Rise time	$I_C=600A, V_{CE}=900V$ $T_{vj}=25^{\circ}C$ $V_{GE}=\pm 15V, R_G=1.0\Omega$ $T_{vj}=125^{\circ}C$ (inductive load) $T_{vj}=150^{\circ}C$	$t_r$		90 105 106		
Turn-off delay time	$I_C=600A, V_{CE}=900V$ $T_{vj}=25^{\circ}C$ $V_{GE}=\pm 15V, R_G=1.0\Omega$ $T_{vj}=125^{\circ}C$ (inductive load) $T_{vj}=150^{\circ}C$	$t_{doff}$		301 341 354		
Fall time	$I_C=600A, V_{CE}=900V$ $T_{vj}=25^{\circ}C$ $V_{GE}=\pm 15V, R_G=1.0\Omega$ $T_{vj}=125^{\circ}C$ (inductive load) $T_{vj}=150^{\circ}C$	$t_f$		274 394 377		
Turn-on energy loss per pulse	$I_C=600A, V_{CE}=900V$ $T_{vj}=25^{\circ}C$ $V_{GE}=\pm 15V, R_G=1.0\Omega$ $T_{vj}=125^{\circ}C$ $di/dt=4400A/\mu s(T_{vj}=150^{\circ}C)$ $T_{vj}=150^{\circ}C$ (inductive load)	$E_{on}$		107.5 159.8 179.6		
Turn-off energy loss per pulse	$I_C=600A, V_{CE}=900V$ $T_{vj}=25^{\circ}C$ $V_{GE}=\pm 15V, R_G=1.0\Omega$ $T_{vj}=125^{\circ}C$ $du/dt=7900V/\mu s(T_{vj}=150^{\circ}C)$ $T_{vj}=150^{\circ}C$ (inductive load)	$E_{off}$		89.3 114.7 122.5		mJ
SC data	$V_{GE} \leq 15V, V_{ce}=1000V$ $V_{CEmax}=V_{CES}-L_{sCE} \cdot di/dt$ $t_p \leq 10\mu s, T_{vj}=125^{\circ}C$	$I_{sc}$		2700		A
Thermal resistance, junction to case	per IGBT	$R_{thJC}$			0.035	K/W
Temperature under switching conditions		$T_{vj op}$	-40		150	$^{\circ}C$

## Diode, Inverter

### Maximum Ratings

Parameter	Conditions	Symbol	Value	Unit
Repetitive peak reverse voltage	$T_{vj}=25^{\circ}\text{C}$	$V_{RRM}$	1700	V
Continuous DC forward current		$I_F$	600	A
Repetitive peak forward current	$t_p=1\text{ms}$	$I_{FRM}$	1200	A
$I^2t$ -value	$t_p=10\text{ms}$ , $\sin 180^{\circ}$ , $T_j=125^{\circ}\text{C}$	$I^2t$	31000	$\text{A}^2\text{s}$

### Characteristic Values

Parameter	Conditions	Symbol	Value			Unit
			Min	Typ	Max	
Forward voltage	$I_F=600\text{A}$ , $V_{GE}=0\text{V}$ $T_{vj}=25^{\circ}\text{C}$	$V_F$		1.98	2.5	V
	$I_F=600\text{A}$ , $V_{GE}=0\text{V}$ $T_{vj}=125^{\circ}\text{C}$		2.20			
	$I_F=600\text{A}$ , $V_{GE}=0\text{V}$ $T_{vj}=150^{\circ}\text{C}$		2.17			
Peak reverse recovery current	$I_F=600\text{A}$ $-\text{di}_F/\text{dt}=4400\text{A}/\mu\text{s}$ ( $T_{vj}=150^{\circ}\text{C}$ ) $V_R=900\text{V}$ , $V_{GE}=-15\text{V}$	$I_{RM}$		307	A	
	$T_{vj}=25^{\circ}\text{C}$		336			
	$T_{vj}=125^{\circ}\text{C}$ $T_{vj}=150^{\circ}\text{C}$		365			
Recovered charge	$I_F=600\text{A}$ $-\text{di}_F/\text{dt}=4400\text{A}/\mu\text{s}$ ( $T_{vj}=150^{\circ}\text{C}$ ) $V_R=900\text{V}$ , $V_{GE}=-15\text{V}$	$Q_r$		86.1	$\mu\text{C}$	
	$T_{vj}=25^{\circ}\text{C}$		145.8			
	$T_{vj}=125^{\circ}\text{C}$ $T_{vj}=150^{\circ}\text{C}$		171.5			
Reverse recovered energy	$I_F=600\text{A}$ $-\text{di}_F/\text{dt}=4600\text{A}/\mu\text{s}$ ( $T_{vj}=150^{\circ}\text{C}$ ) $V_R=900\text{V}$ , $V_{GE}=-15\text{V}$	$E_{rec}$		49.9	mJ	
	$T_{vj}=25^{\circ}\text{C}$		87.1			
	$T_{vj}=125^{\circ}\text{C}$ $T_{vj}=150^{\circ}\text{C}$		102.8			
Thermal resistance, junction to case	per diode	$R_{thJC}$			0.077	K/W
Temperature under switching conditions		$T_{vj\text{ op}}$	-40		150	$^{\circ}\text{C}$

## NTC-Thermistor

### Characteristic Values

Parameter	Conditions	Symbol	Value			Unit
			Min.	Typ.	Max.	
Rated resistances	$T_c=25^{\circ}\text{C}$ , $\pm 5\%$	$R_{25}$		5.0		k $\Omega$
B-value	$\pm 2\%$	$B_{25/50}$		3375		K

## Module

Parameter	Conditions	Symbol	Value			Unit
Isolation test voltage	RMS, f=50Hz, t=1min	$V_{ISOL}$	4000			V
Internal isolation			$\text{Al}_2\text{O}_3$			
Storage temperature		$T_{stg}$	-40		125	$^{\circ}\text{C}$
Mounting torque for modul mounting		M	3.0		6.0	Nm
Terminal connection torque		M	3.0		6.0	Nm
Weight		W		345		g

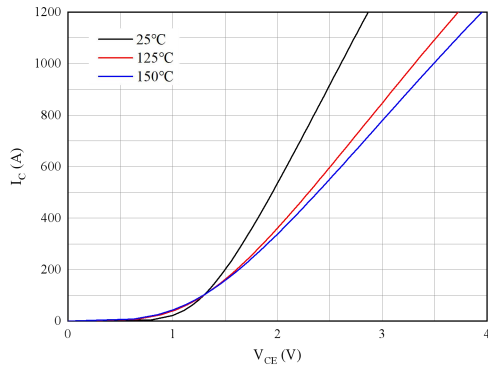

Fig 1. Typical output characteristics ( $V_{GE}=15V$ )

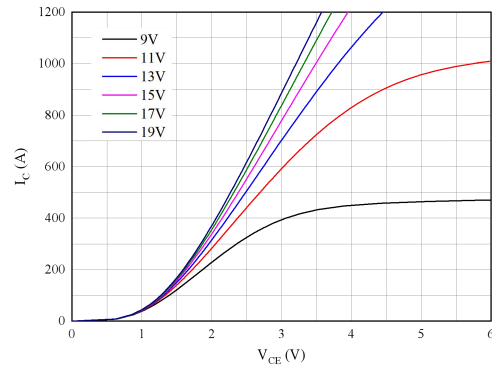

Fig 2. Typical output characteristics ( $T_{vj}=150^{\circ}C$ )

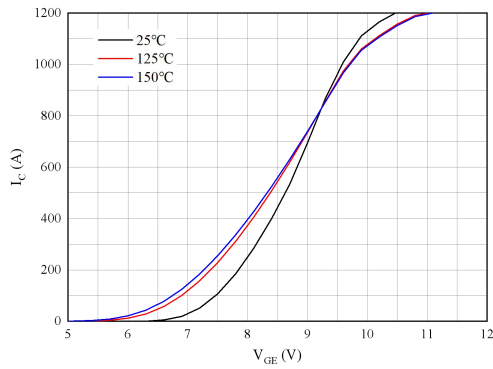

Fig 3. Typical transfer characteristic ( $V_{CE}=20V$ )

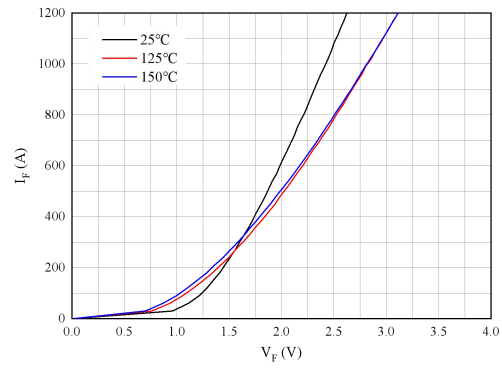

Fig 4. Forward characteristic of Diode

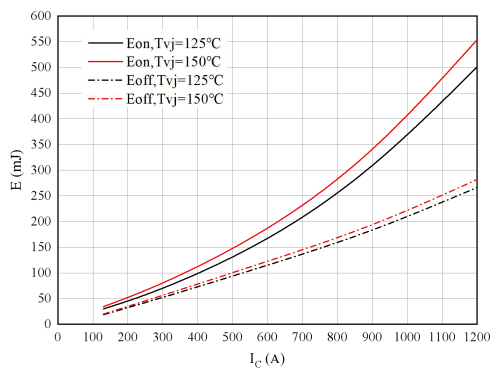

Fig 5. Switching losses of IGBT

$V_{GE}=\pm 15V, R_{Gon}=1.0\Omega, R_{Goff}=1.0\Omega, V_{CE}=900V$

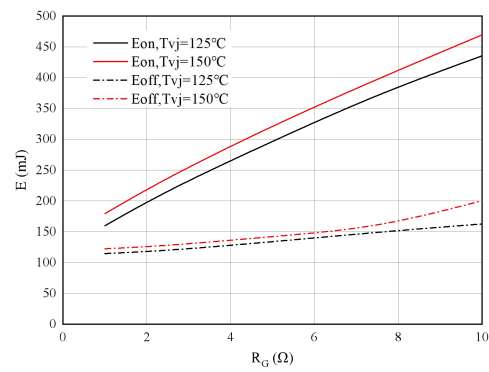

Fig 6. Switching losses of IGBT

$V_{GE}=\pm 15V, I_C=600A, V_{CE}=900V$

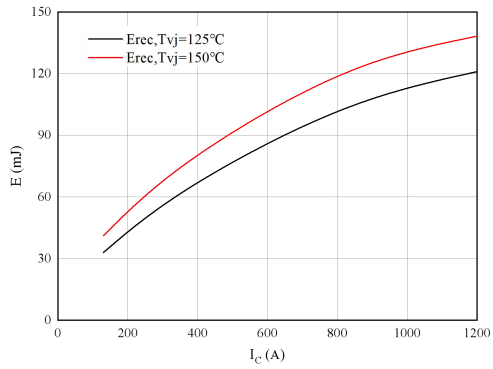

Fig 7. Switching losses of Diode

R<sub>Gon</sub>=1.0Ω, V<sub>CE</sub>=900V

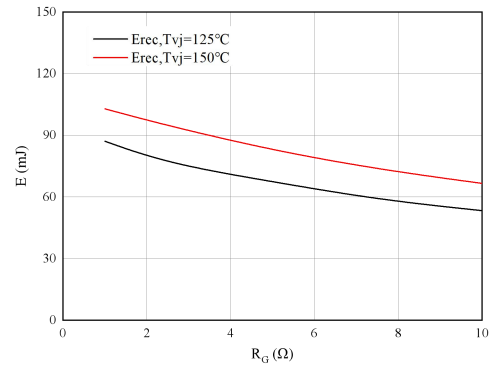

Fig 8. Switching losses of Diode

I<sub>F</sub>=600A, V<sub>CE</sub>=900V

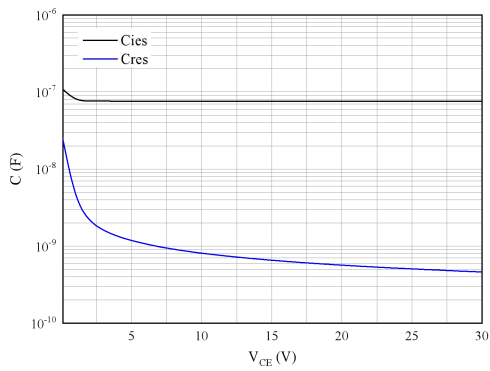

Fig 9. Capacitance characteristic

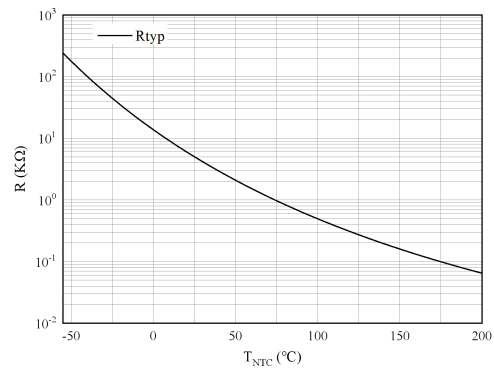

Fig 10. NTC-Themistor-temperature characteristic

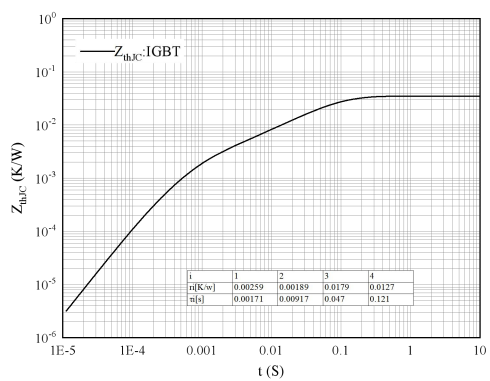

Fig 11. Transient thermal impedance IGBT, Inverter  
Figure 11. Z<sub>thJC</sub>=f(t)

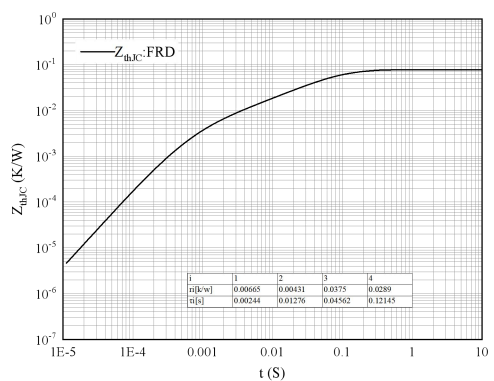
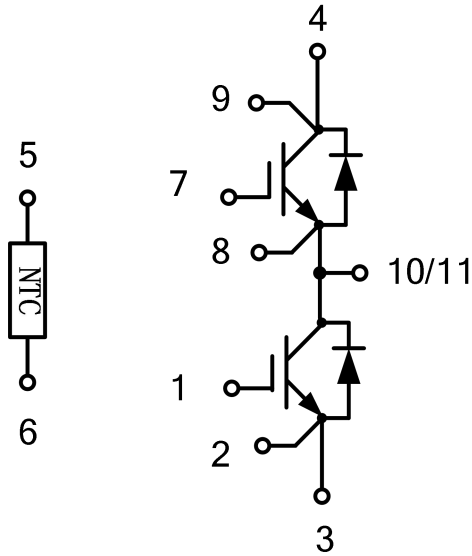

Fig 12. Transient thermal impedance FRD, Inverter  
Figure 12. Z<sub>thJC</sub>=f(t)

**Circuit diagram**



**Package outlines**

