

1200V 40mΩ N-Channel SiC Power MOSFET

Description

The AKCT40N120H4L is a high blocking voltage N-Channel SiC power MOSFET. This device provide excellent performance for high voltage power supplies or pulse circuits.

Features

- Typical on-Resistance: $R_{DS(on)}=40m\Omega$ (typ.)
- High Blocking Voltage
- 100% Avalanche Test
- Good Stability and Uniformity with High E_{AS}

Applications

- Solar Inverters
- High Voltage DC/DC Converters
- Motor Drivers
- Switch Mode Power Supplies

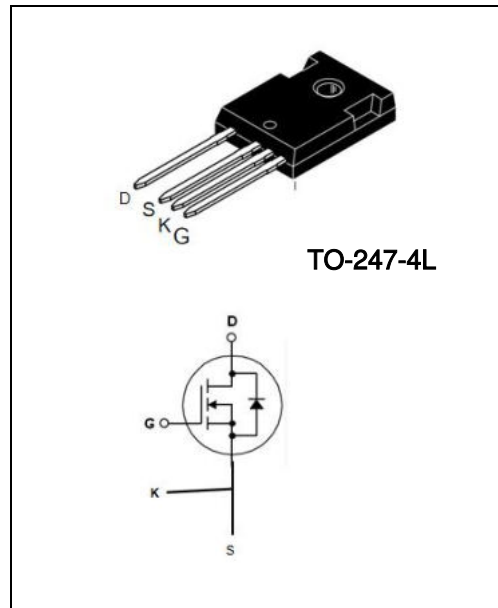

Absolute Maximum Ratings @ $T_C=25^\circ C$ unless otherwise noted

| Symbol | Parameter | Ratings | Unit | |
|------------|--|-------------------|------------|---------------|
| V_{DSS} | Drain to Source Voltage | 1200 | V | |
| V_{GSS} | Gate to Source Voltage | -10/+25 | V | |
| V_{GSop} | Recommended operation Values of Gate –Source Voltage | -5/+20 | V | |
| I_D | Drain Current | $T_C=25^\circ C$ | 61 | A |
| | | $T_C=100^\circ C$ | 42 | A |
| I_{DM} | Pulsed Drain Current (Note1) | 120 | A | |
| P_D | Maximum Power Dissipation | $T_C=25^\circ C$ | 250 | W |
| | Derate above $25^\circ C$ | | 1.67 | W/ $^\circ C$ |
| E_{AS} | Single Pulsed Avalanche Energy (Note 2) | 300 | mJ | |
| T_J | Operating Junction Temperature Range | -50~+175 | $^\circ C$ | |
| T_{STG} | Storage Temperature Range | -50~+175 | $^\circ C$ | |

Thermal Characteristics

| Symbol | Parameter | Ratings | Unit |
|---------------|---|---------|--------------|
| $R_{th(J-C)}$ | Thermal Resistance, Junction to case | 0.6 | $^\circ C/W$ |
| $R_{th(J-A)}$ | Thermal Resistance, Junction to Ambient | 40 | $^\circ C/W$ |

Electrical Characteristics @ $T_c=25\text{ }^\circ\text{C}$ unless otherwise noted

| Symbol | Parameter | Conditions | Min. | Typ. | Max. | Unit |
|--------------|-----------------------------------|-----------------------------|------|------|-----------|------------|
| BV_{DSS} | Drain to Source Breakdown Voltage | $V_{GS}=0V, I_D=2mA$ | 1200 | - | - | V |
| $V_{GS(th)}$ | Gate Threshold Voltage | $V_{DS}=V_{GS}, I_D=5mA$ | 2.0 | 2.5 | 4.0 | V |
| $R_{DS(on)}$ | Static Drain-Source On-Resistance | $V_{GS}=20V, I_D=20A$ | - | 44 | 65 | m Ω |
| I_{DSS} | Zero Gate Voltage Drain Current | $V_{DS}=V_{DSS}, V_{GS}=0V$ | - | - | 100 | μA |
| I_{GSS} | Gate to Source Leakage Current | $V_{GS}=V_{GSS}, V_{DS}=0V$ | - | - | ± 500 | nA |

D-S Diode Characteristics and Maximum Rating @ $T_c=25\text{ }^\circ\text{C}$ unless otherwise noted

| Symbol | Parameter | Conditions | Min. | Typ. | Max. | Unit |
|----------|------------------------------------|--|------|------|------|------|
| V_{SD} | Drain-Source Diode Forward Voltage | $V_{GS}=0V, I_S=40A$ | - | 3.9 | - | V |
| t_{rr} | Reverse Recovery Time | $V_{GS}=0V, I_S=40A,$ $di/dt=-290A/\mu s$ | - | 30 | - | ns |
| Q_{rr} | Reverse Recovery Charge | | - | 590 | - | nC |

Switching Characteristics @ $T_c=25\text{ }^\circ\text{C}$ unless otherwise noted

| Symbol | Parameter | Conditions | Min. | Typ. | Max. | Unit |
|--------------|------------------------------|---|------|------|------|------|
| $t_{d(on)}$ | Turn-on Delay Time | $I_D=40A,$ $V_{DD}=800V,$ $R_G=2.5\Omega$ $V_{GS}=-5/20V,$ (Note 3) | - | 12 | - | ns |
| t_r | Turn-on Rise Time | | - | 12 | - | ns |
| $t_{d(off)}$ | Turn-off Delay Time | | - | 23 | - | ns |
| t_f | Turn-off Fall Time | | - | 6.7 | - | ns |
| C_{iss} | Input Capacitance | $V_{GS}=0V, V_{DS}=1000V,$ $f=1.0MHz$ | - | 2946 | - | pF |
| C_{oss} | Output Capacitance | | - | 167 | - | pF |
| C_{riss} | Reverse Transfer Capacitance | | - | 6.6 | - | pF |
| Q_g | Total Gate Charge | $I_D=40A,$ $V_{DD}=800V$ $V_{GS}=-5V/20V$ (Note 3) | - | 142 | - | nC |
| Q_{ge} | Gate to Source Charge | | - | 37 | - | nC |
| Q_{gd} | Gate to Drain Charge | | - | 18 | - | nC |

Note:

1. Repetitive rating: pulse-width limited by maximum junction temperature
2. $V_{DD}=100V, L=10mH, V_{clamp}=1600V, V_G=10V, I_D=19.0A$
3. Essentially independent of operating temperature typical characteristics

Typical Performance Characteristics

Fig. 1. Typical on-Resistance Characteristics

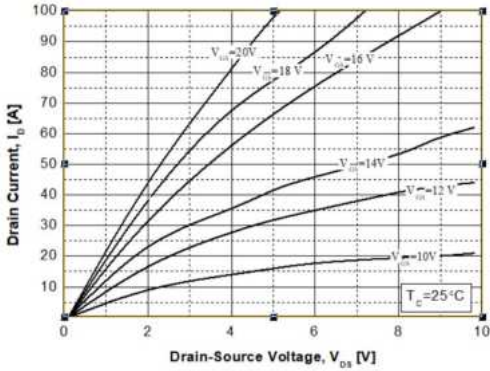

Fig. 2. Normalized On-Resistance vs. Drain Current and Gate Voltage

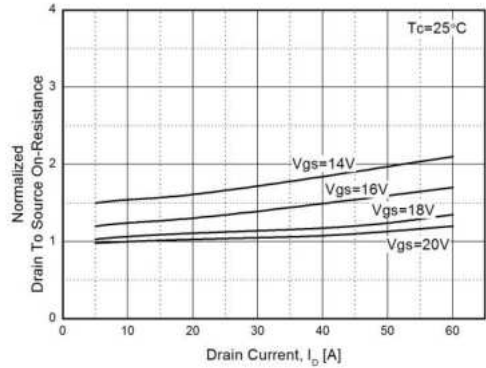

Fig. 3. Normalized On-Resistance vs. Junction Temperature

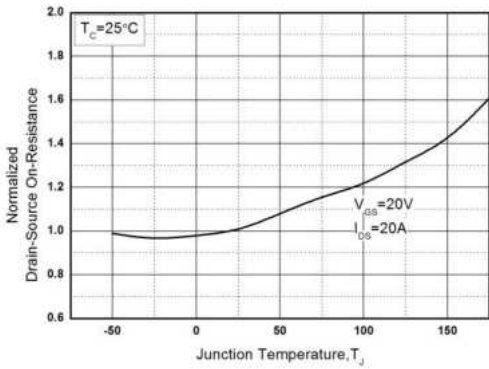

Fig. 4. On-Resistance vs. Gate-to-source Voltage

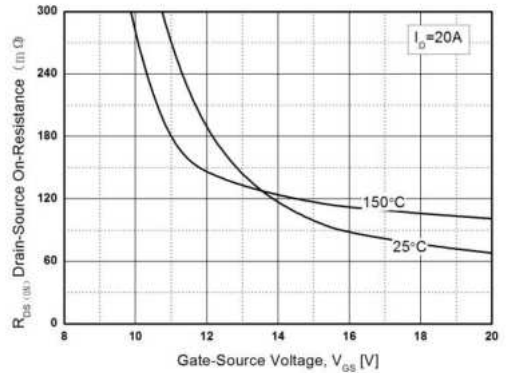

Fig. 5. Transfer Characteristics

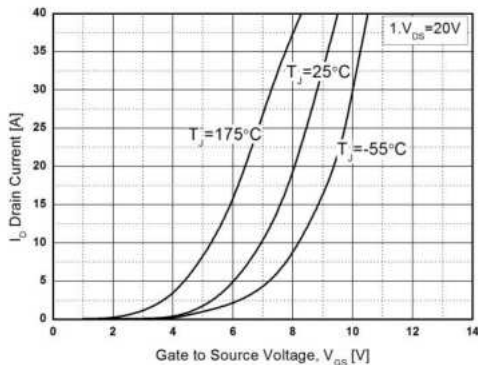
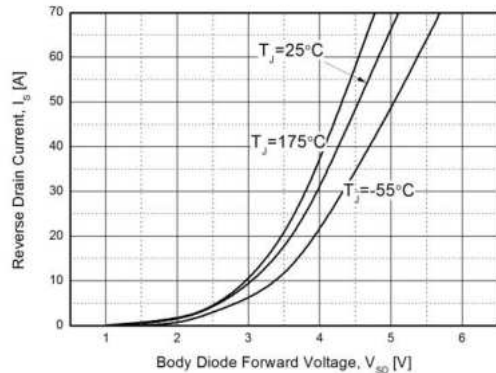

Fig. 6. Source-to-Drain Diode Forward Voltage vs. Source Current



Typical Performance Characteristics

Fig. 7. Gate Charge Characteristics

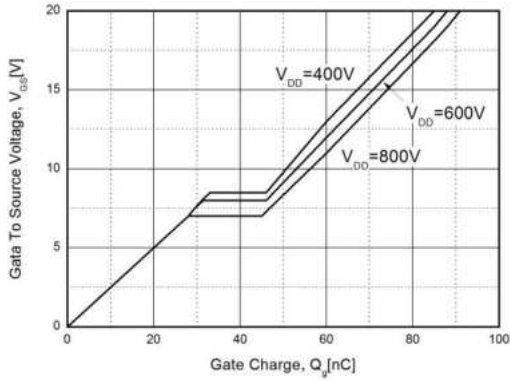

Fig. 8. Characteristics vs. Drain-to-Source Voltage

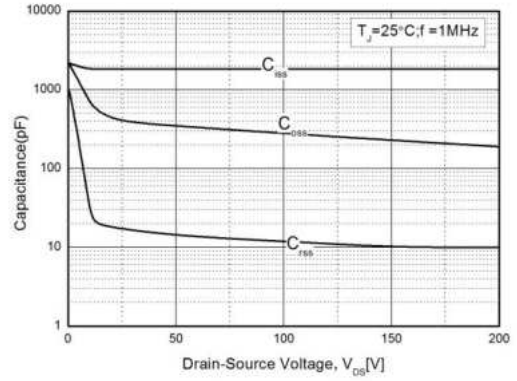
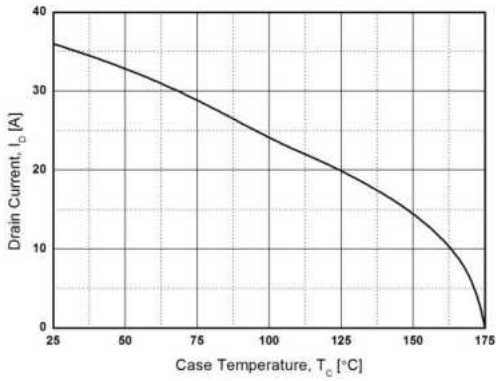

Fig. 9. Maximum Drain Current vs. Temperature



Package Dimensions

TO-247-4L

(Dimensions in Millimeters)

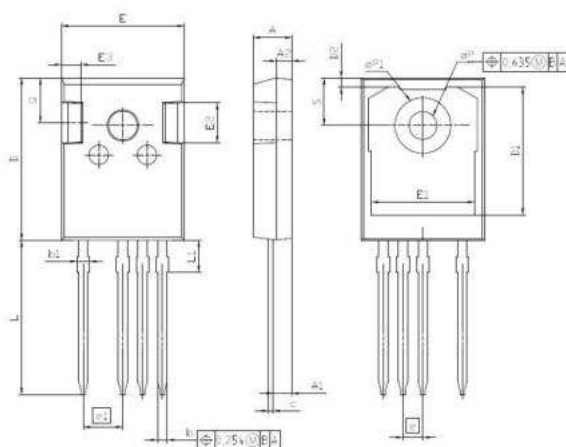

| DIM | MILLIMETERS | | INCHES | |
|-----|-------------|-------|-------------|-------|
| | MIN | MAX | MIN | MAX |
| A | 4.83 | 5.21 | 0.190 | 0.205 |
| A1 | 2.29 | 2.54 | 0.090 | 0.100 |
| A2 | 1.90 | 2.16 | 0.075 | 0.085 |
| b | 1.07 | 1.33 | 0.042 | 0.052 |
| b1 | 1.10 | 1.70 | 0.043 | 0.067 |
| c | 0.50 | 0.70 | 0.020 | 0.028 |
| D | 20.80 | 21.10 | 0.819 | 0.831 |
| D1 | 16.25 | 17.65 | 0.640 | 0.695 |
| D2 | 0.95 | 1.35 | 0.037 | 0.053 |
| E | 15.70 | 16.13 | 0.618 | 0.635 |
| E1 | 13.10 | 14.15 | 0.516 | 0.557 |
| E2 | 3.68 | 5.10 | 0.145 | 0.201 |
| E3 | 1.00 | 2.60 | 0.039 | 0.102 |
| e | 2.54 (BSC) | | 0.100 (BSC) | |
| e1 | 5.08 | | 0.200 | |
| N | 4 | | 4 | |
| L | 19.72 | 20.32 | 0.776 | 0.800 |
| L1 | 4.02 | 4.40 | 0.158 | 0.173 |
| øP | 3.50 | 3.70 | 0.138 | 0.146 |
| øP1 | 7.00 | 7.40 | 0.276 | 0.291 |
| Q | 5.49 | 6.00 | 0.216 | 0.236 |
| S | 6.04 | 6.30 | 0.238 | 0.248 |